



BALANCED PRESSURE THERMOSTATIC STEAM TRAP

MODEL FL21/FL32 QuickTrap®

BALANCED PRESSURE THERMOSTATIC TRAP WITH "FAIL OPEN" DESIGN

Features

Inline replaceable and cleanable 2-bolt universal flange steam trap with high air venting capability. For steam mains, tracers, dryers and heaters.

1. Two-bolt flange connector permits trap replacement or cleaning in minutes without disturbing piping.
2. Universal flange allows trap to be positioned in the correct attitude, regardless of pipeline configuration.
3. Patented "fail open" feature for critical service.
4. Rugged yet light construction withstands superheat and water hammer.
5. Cyclic operation with fixed subcooling throughout the whole pressure range.
6. Built-in screens in connector and trap body protect and keep trap module replacement costs low.
7. Easily cleanable and repairable design.
8. Hardened stainless steel valve head and seat.
9. Models FL21C and FL32C with built-in check valve available upon request.



Specifications

Model	FL21	FL32
Connection	Screwed, Socket Welded, Flanged	
Size	1/2", 3/4", 1" / DN 15, 20, 25	
Max. Operating Pressure (barg) PMO	21	32
Min. Operating Pressure (barg)	0.1	
Maximum Back Pressure	90% of inlet pressure	
Max. Operating Temp. (°C) TMO	see graph at right	
Subcooling of X-element Fill (°C)	up to 6	
Type of X-element	B	

PRESSURE SHELL DESIGN CONDITIONS

1 bar = 0.1 MPa

(NOT OPERATING CONDITIONS): Maximum Allowable Pressure (barg) PMA: 32
Maximum Allowable Temperature (°C) TMA: 300

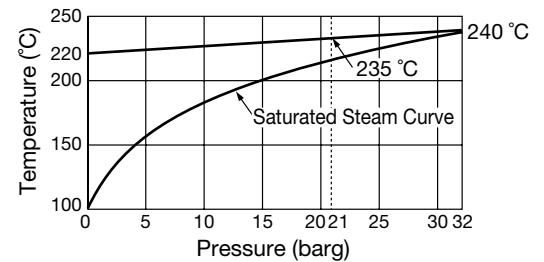

CAUTION To avoid abnormal operation, accidents or serious injury, DO NOT use this product outside of the specification range. Local regulations may restrict the use of this product to below the conditions quoted.

No.	Description	Material	DIN*	ASTM/AISI*
①	Trap Body	Cast Stainless Steel A351 Gr. CF8	1.4312	—
②	Connector Body	Cast Stainless Steel A351 Gr. CF8	1.4312	—
③	Connecting Flange	Carbon Steel A105	1.0460	—
④	Snap Ring	Carbon Steel SWRH57	1.0535	AISI1055
⑤ ^{MR}	Outer Connector Gasket	Stainl. Stl. SUS304/Graphite	1.4301	AISI304
⑥ ^{MR}	Inner Connector Gasket	Stainl. Stl. SUS304/Graphite	1.4301	AISI304
⑦ ^R	Valve Seat	Stainless Steel SUS420F	1.4028	AISI420F
⑧	Trap Cover	Carbon Steel C22.8	1.0460	A105
⑨ ^{MR}	Cover Gasket	Stainl. Stl. SUS316L/Graphite	1.4404	AISI316L
⑩ ^R	Connector Screen	Stainless Steel SUS304/430	1.4301/4016	AISI304/430
⑪ ^{MR}	Screen Holder Gasket	Stainless Steel SUS316L	1.4404	AISI316L
⑫	Screen Holder	Stainless Steel SUS303	1.4305	AISI303
⑬ ^R	X-element	Stainless Steel	—	—
⑭ ^R	X-element Guide	Stainless Steel SUS304	1.4301	AISI304
⑮	Nameplate	Stainless Steel SUS304	1.4301	AISI304
⑯ ^R	Spring Clip	Stainless Steel SUS304	1.4301	AISI304
⑰	Cover Bolt	Carbon Steel S45C	1.0503	AISI1045
⑱	Trap Screen	Stainless Steel SUS304	1.4301	AISI304
⑲	Connector Bolt**	Alloy Steel SNB7	1.7225	A193 Gr. B7
⑳	Flange**	Cast Stainless Steel A351 Gr. CF8	1.4312	—

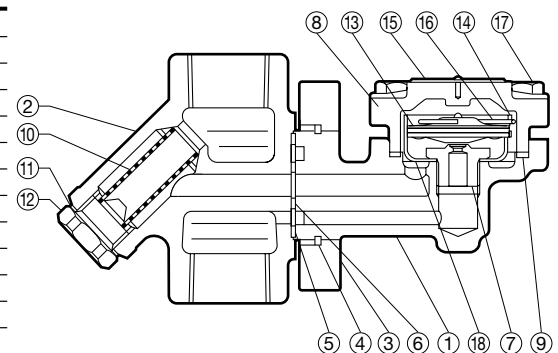

* Equivalent materials ** Shown overleaf
Replacement kits available: (M) maintenance parts, (R) repair parts

Dimensions

● **FL21/FL32**
Screwed

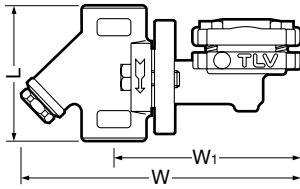

● **FL21/FL32**
Socket Welded

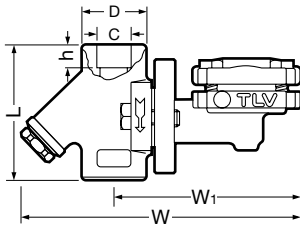

● **FL21/FL32**
Flanged

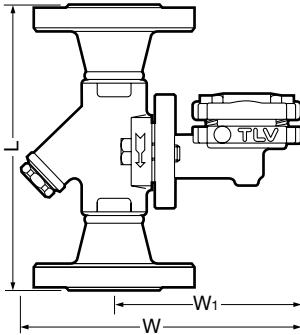

FL21/FL32 Screwed* (mm)

Size	L	W	W ₁	Weight (kg)
1/2"	80	161	105	1.8
3/4"				
1"	96	184	109	2.1

* BSP DIN 2999, other standards available

FL21/FL32 Socket Welded* (mm)

DN	L	W	W ₁	φC	φD	h	Weight (kg)
15	80	161	105	21.70	37	13	1.8
20				27.05			
25	96	184	109	33.80	44		2.1

* ASME B16.11, other standards available

FL21/FL32 Flanged (mm)

DN	L				W	W ₁	Weight* (kg)
	DIN 2501 PN25/40	ASME Class					
		150RF	300RF	600RF			
15	150	140	140	140	161	105	4.8
20		165	165	165			5.3
25	160	210	210	210			6.4

Other standards available, but length and weight may vary

* Weight is for DIN PN 25/40

Discharge Capacity

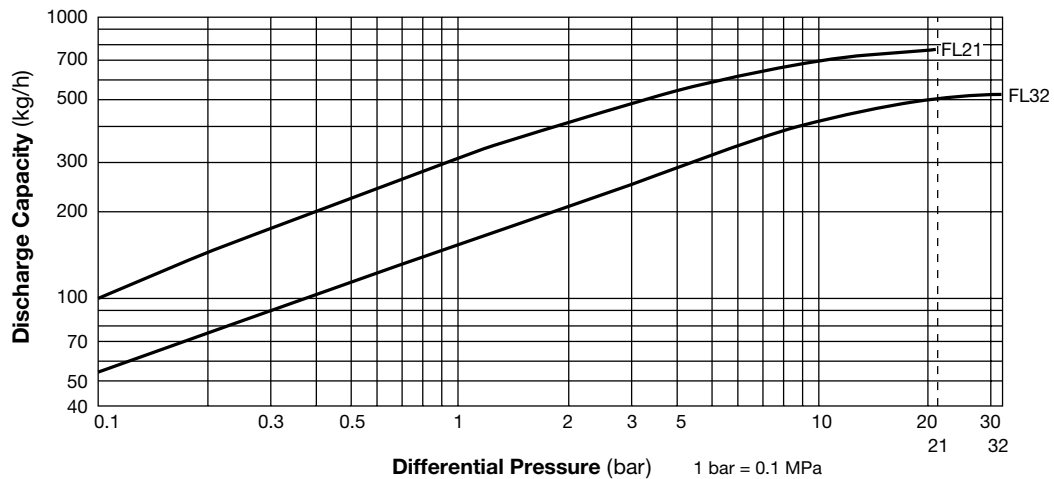

1. Differential pressure is the difference between the inlet and outlet pressure of the trap.
2. Recommended safety factor: at least 2.

Manufacturer
TLV[®] CO., LTD.
Kakogawa, Japan
is approved by LRQA Ltd. to ISO 9001/14001

ISO 9001/ISO 14001

